

Model 6061C

Side Exit High-Temp Industrial Accelerometer

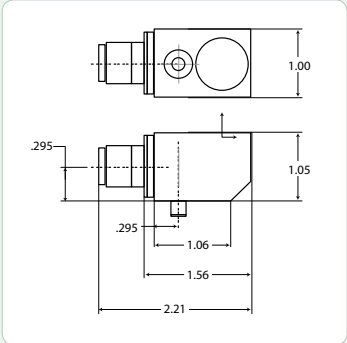

DESCRIPTION AND FEATURES

- 100 mV/g
- Welded Hermetic Seal
- 2-Pin MIL Style Connector
- Use on surface temperature of up to 350°F with Thermal Isolator in room temperature ambient air.

APPLICATIONS

- General Industrial
- Motors/Generators
- Pumps
- Gearboxes
- Rollers
- Experimental
- Fans/Cooling Towers
- Bearing Housings
- Compressors

OPERATING SPECIFICATIONS

Dynamic

Sensitivity @ 100 Hz, ± 10%	100 mV/g
Frequency Range ± 5%	5 Hz - 4 kHz
Frequency Range ± 10%	4 Hz - 7 kHz
Frequency Range ± 3 dB	2 Hz - 12 kHz
Turn-On Time	< 0.5 Seconds
Amplitude Range	± 70 g-pk
	(Above 250°F: ±40g pk.)
Mounted Resonance (nominal)	> 18 kHz
Transverse Sensitivity	< 5%
Amplitude Linearity	< 1%

Electrical

Noise Broadband 2.5 Hz to 20 kHz	350 µg
Noise Spectral 10 Hz	30 µg/√Hz
Noise Spectral 100 Hz	8 µg/√Hz
Noise Spectral 1000 Hz	3 µg/√Hz
Output Impedance	< 100 Ω
Grounding	Isolated
Bias Volts	12-14 VDC
Power Requirements	24-30 VDC
Current Regulating Diode	2-6 mA cc

Environmental

Temperature Range	-40 to 300°F / -40 to 150°C
Base Strain (NOM)	.005 g peak/µstrain
Shock Limit	5,000 g-pk

Physical

Dimensions	1.05" H x 2.2" L x 1" W
Weight	154 grams
Case Material	Type 304L Stainless Steel
Design	Piezoelectric Compression
Seal	Welded - Hermetic
Mounting	1/4-28 stud
Mounting Torque	35 in-lb (3.9 N-m)

ORDERING INFORMATION AND ACCESSORIES

Model 6061C, Mfr. Part No. 6061C-5015	
Power Supplies, 2 mA output, BNC/BNC, 24 VDC	
Model P5000 (rechargeable battery)	9356559
Model LP24-1B (110 VAC Line Input)	9356120
Thermal Isolator	9356736-10, 14
Cable, 2-Pin MIL/Pigtail 6' high temp	9354084
Cable, 2-Pin MIL/BNC 6' high temperature	9356381
Magnetic holder, 16 lb (for curved/flat surfaces)	9356809

Sensors include

NIST Traceable Calibration, 1/4-28 Mounting Stud
User Manual, 1-Year Warranty

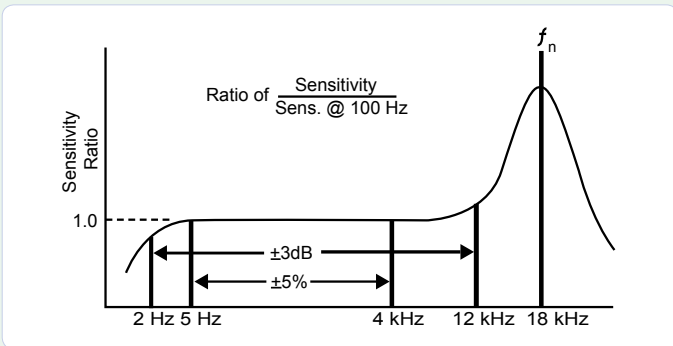

WORLDWIDE HEADQUARTERS:
195 Clarksville Rd •
Princeton Jct, NJ 08550 • USA
T: +1.609.716.4000 • F: +1.609.716.0706
E-MAIL: sales.systems@mistrasgroup.com

CANADA T: +1.403.556.1350
CHINA T: +86.10.5877.3672
FRANCE T: +331.498.26040
GERMANY T: +49.040.2000.4025
GREECE T: +30.210.2846.801

HOLLAND T: +31.010.245.0325
INDIA T: +91.22.2586.2444
JAPAN T: +81.33.498.3570
MIDDLE EAST T: +44(0)1954.231.612
RUSSIA T: +7495.789.4549

SCANDINAVIA T: +46(0)31.252040
S. AMERICA T: +55.11.3082.5111
UK T: +44(0)1954.231.612